

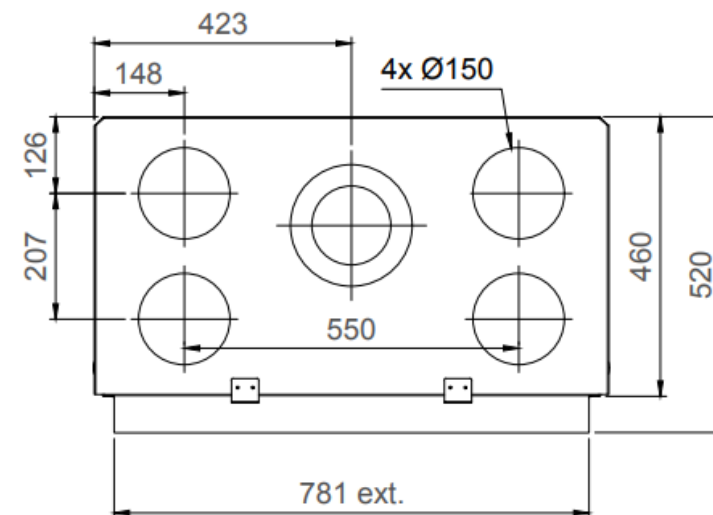

TRUE VISION 850 V

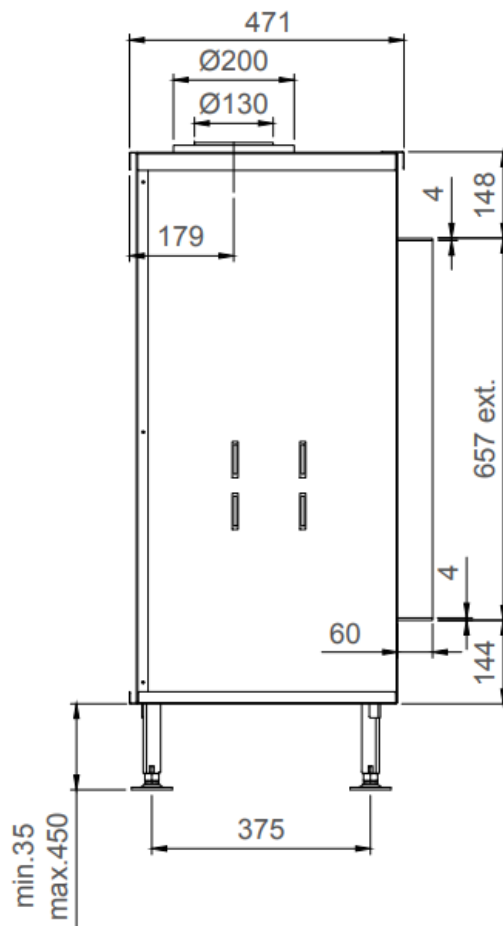
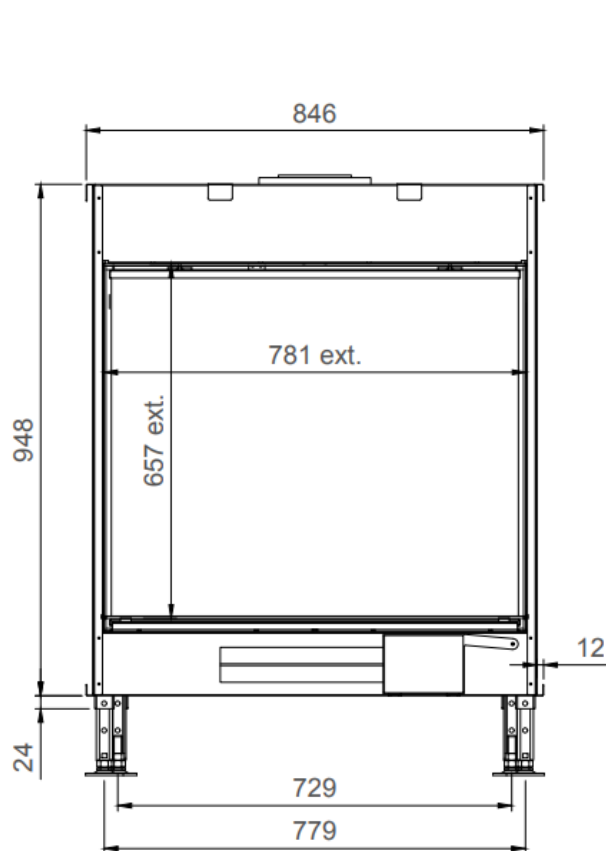

DE SMARTE LØSNINGENE:

Direkte tenning

Åpne/lukke glass,
ingen demontering

Luftregulering i
brennkammer

M-design peiser kan
styres med
smarttelefon/nettbrett.

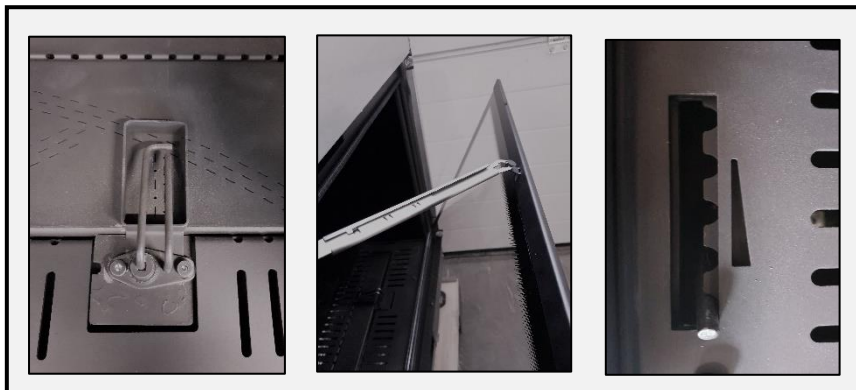

Ved sett H1



Ved sett H2



Effekt (Min-maks).....	3-11 kw
Virkningsgrad.....	81% (LPG70%)
Vekt	145 kg
Energimerking	C
Avgass størrelse	ø200/130mm
Eco Wave/Eco Switch.....	standard